

Model F381 Series Filter

SPECIFICATIONS

Element	Stainless steel woven mesh
Size(s)	5, 10, and 30 micron
Maximum Operating Pressure	3000 psi (207 bar)
Flow Rate (at 3 cP)	up to 70 liters/min
Port Size(s)	3/8" NPT, #6 SAE, 3/8 BSPP
Weight	1.34 kg



MATERIALS OF CONSTRUCTION

Body	Stainless steel, type 303
Element	Stainless steel, type 304
Seals	Standard: Viton® Optional: Teflon®, Neoprene, Perfluoroelastomer

DIMENSIONS

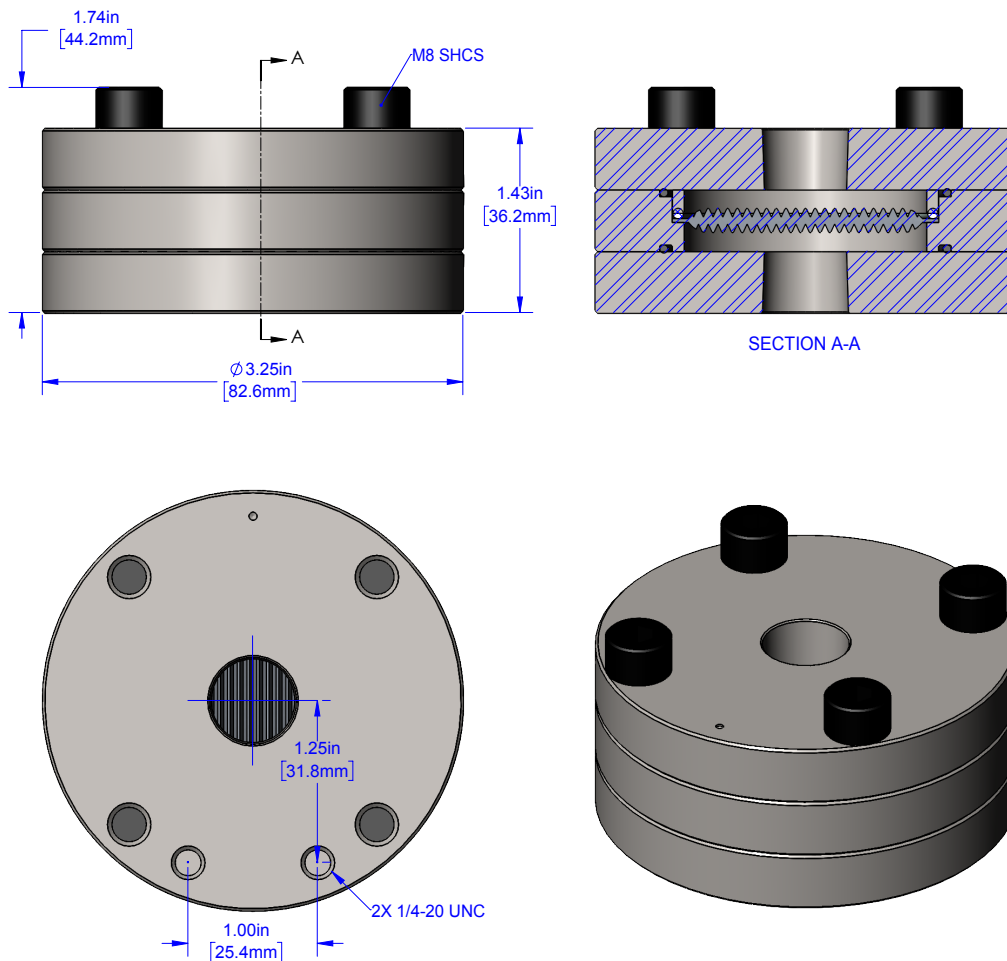

Model F381 Series Filter

5 Micron Filter

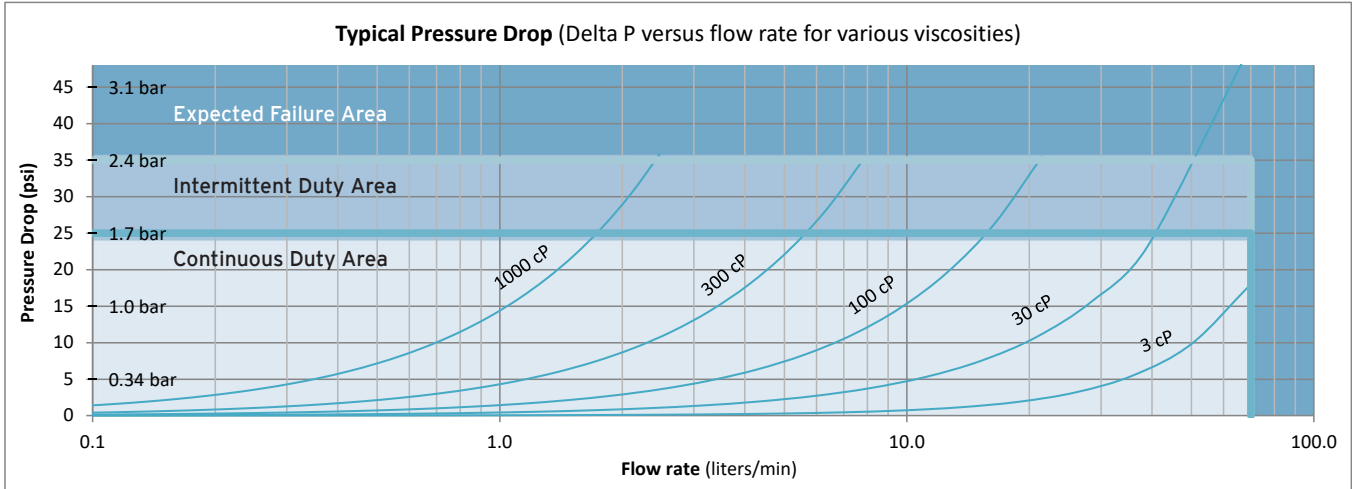

10 Micron Filter

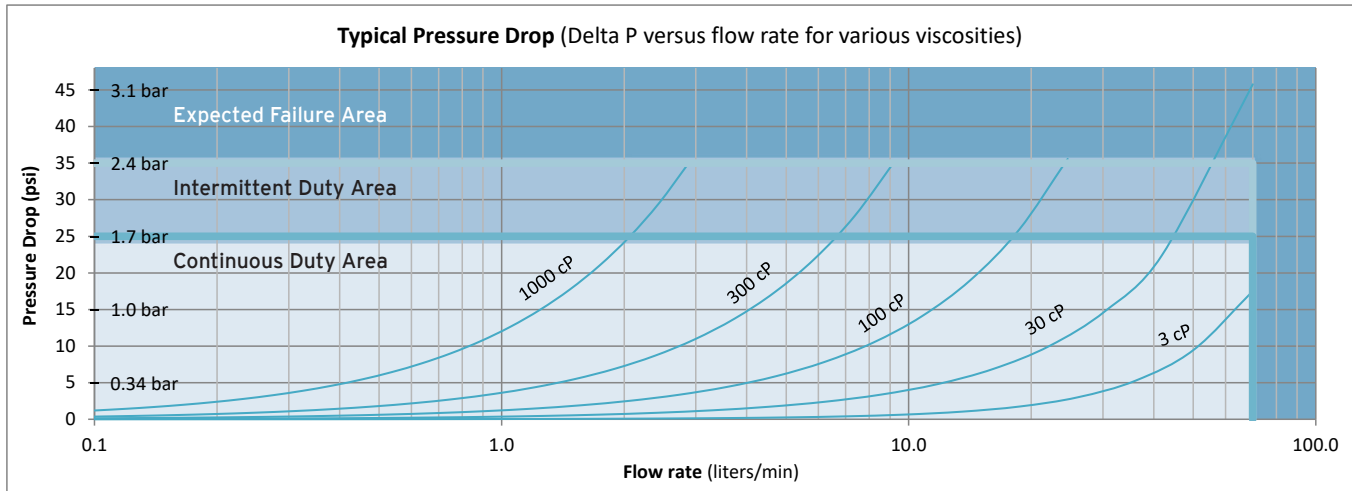

30 Micron Filter

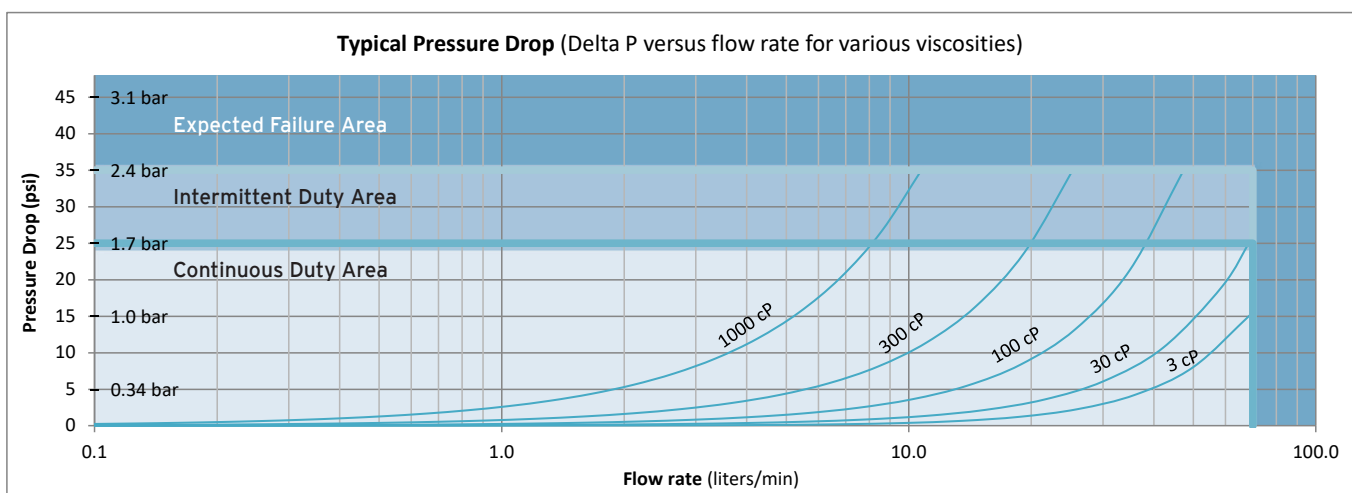



F-Series Filters 3000 psi (210 bar) rated

Filter Selections

Model # - - -

Fluid Connection

NPT	NPT
SAE	SAE
BSPP	BSP

Filtration Level

5 Micron	5
10 Micron	10
30 Micron	30

Seal Selection

Viton® - FKM	VIT
Teflon® - PTFE	TEF
Perfluoroelastomer - FFKM	PER
Neoprene	NEO

Replacement Filter Element Selections

Model # - -

Filtration Level

5 Micron	103
10 Micron	102
30 Micron	104

Seal Selection

Viton® - FKM	705
Teflon® - PTFE	725
Perfluoroelastomer - FFKM	765
Neoprene	715

